

ITEM NO.	QTY.	PART NO.	DESCRIPTION
1	1	Mini screwless vise base	
2	1	Movable Jaw	
3	1	Stationary Jaw	
4	1	Pivot Button	
5	1	Lock stud	
6	1	HX-SHCS 0.19-32x1.5x1.5-S	
7	2	HX-SHCS 0.19-32x1.25x1.25-S	

REVISIONS		DATE	APPROVED
ZONE	REV.	DESCRIPTION	

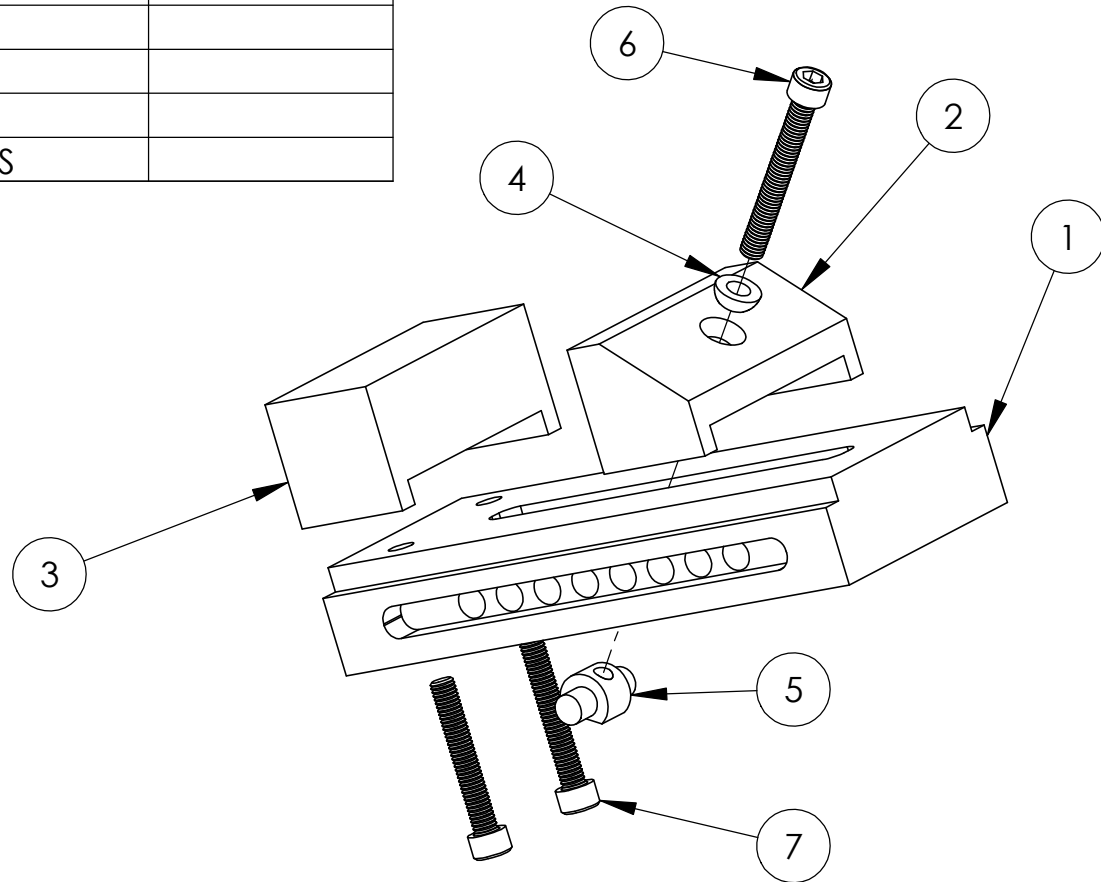
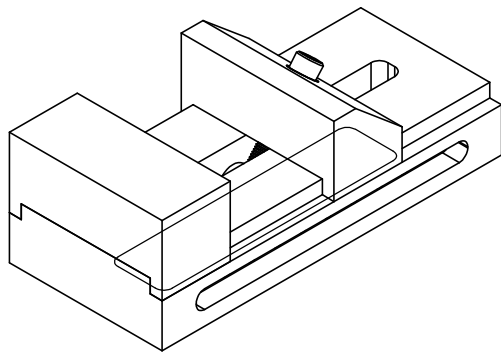

PROPRIETARY AND CONFIDENTIAL
 THE INFORMATION CONTAINED IN THIS DRAWING IS THE SOLE PROPERTY OF DEAN WILLIAMS. ANY REPRODUCTION IN PART OR AS A WHOLE WITHOUT THE WRITTEN PERMISSION OF DEAN WILLIAMS IS PROHIBITED.

UNLESS OTHERWISE SPECIFIED:		NAME	DATE
DIMENSIONS ARE IN INCHES		SCC	5/11/09
TOLERANCES:			
FRACTIONAL ±			
ANGULAR: MACH ± BEND ±			
TWO PLACE DECIMAL ±			
THREE PLACE DECIMAL ±			
INTERPRET GEOMETRIC TOLERANCING PER:			
MATERIAL			
FINISH			
NEXT ASSY	USED ON		
APPLICATION		DO NOT SCALE DRAWING	

Dean's Photographica

TITLE:
MINI SCREWLESS VISE

SIZE	DWG. NO.	REV
A		
SCALE: 1:1.5	WEIGHT:	SHEET 1 OF 4

		REVISIONS			
ZONE	REV.	DESCRIPTION	DATE	APPROVED	

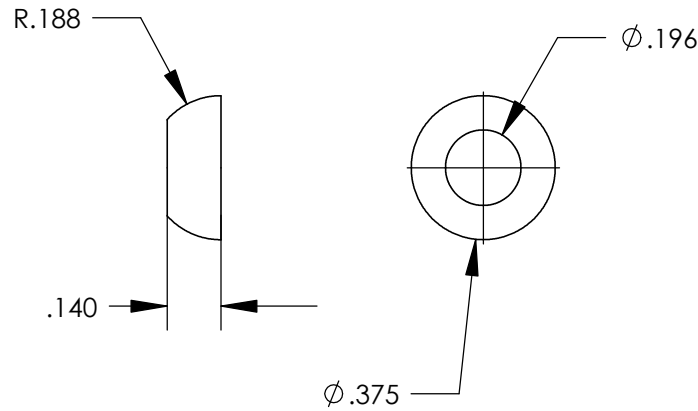

PIVOT BUTTON

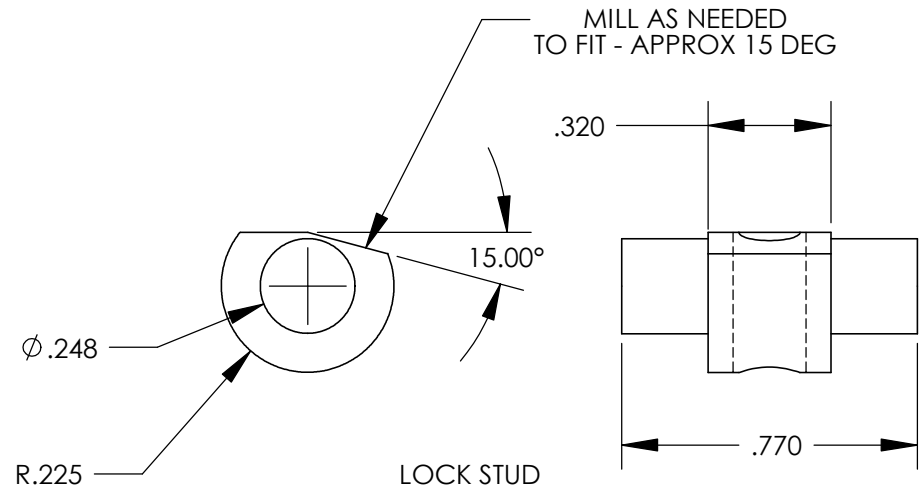
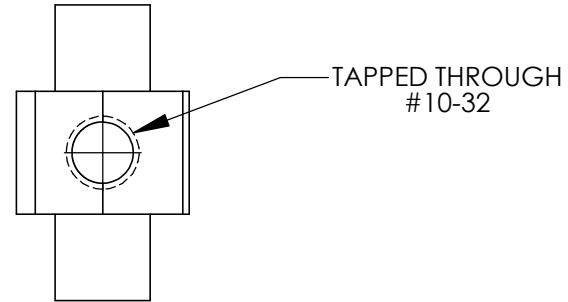

LOCK STUD

PROPRIETARY AND CONFIDENTIAL
 THE INFORMATION CONTAINED IN THIS DRAWING IS THE SOLE PROPERTY OF DEAN WILLIAMS. ANY REPRODUCTION IN PART OR AS A WHOLE WITHOUT THE WRITTEN PERMISSION OF DEAN WILLIAMS IS PROHIBITED.

		UNLESS OTHERWISE SPECIFIED:		NAME	DATE
		DIMENSIONS ARE IN INCHES	DRAWN	SCC	5/11/09
		TOLERANCES:	CHECKED		
		FRACTIONAL ±	ENG APPR.		
		ANGULAR: MACH ± BEND ±	MFG APPR.		
		TWO PLACE DECIMAL ±	Q.A.		
		THREE PLACE DECIMAL ±	COMMENTS:		
		INTERPRET GEOMETRIC TOLERANCING PER:			
		MATERIAL			
		CRS			
		FINISH			
NEXT ASSY	USED ON				
APPLICATION		DO NOT SCALE DRAWING			

Dean's Photographica

TITLE: PIVOT BUTTON AND LOCK STUD

SIZE	DWG. NO.	REV
A		
SCALE: 2:1	WEIGHT:	SHEET 4 OF 4